

HIGH BODY ROOF TROLLEYS

ROSTEK ARMSTRONG & ROCA HIGH BODY ROOF TROLLEYS

Rostek's light roof trolleys are an excellent solution for providing suspended stage access while also being able to hide the rails from sight.

They offer a non-visual facade access solution for every building. The roof trolley does not disturb facade aesthetics as it is hidden on the top of the building. Therefore, the roof trolley system is chosen if monorails are not accepted on the facade.



HOW IT IS USED

Roof trolleys are used in conjunction with a Rostek BMU cradle or suspended platform. Thanks to the low weight of the roof trolley it is well suited for light roof structures. The roof trolley is traversing on Rostek aluminium tracks which can be bent according to the building shape.

Rostek Roof Trolleys can be used in all environments and conditions; from snow to sun. Roof trolleys can be painted to a colour of your choice.

HOW IT WORKS

Lightweight aluminium tracks are installed on top of the roof structure. Three roof trolleys are available.

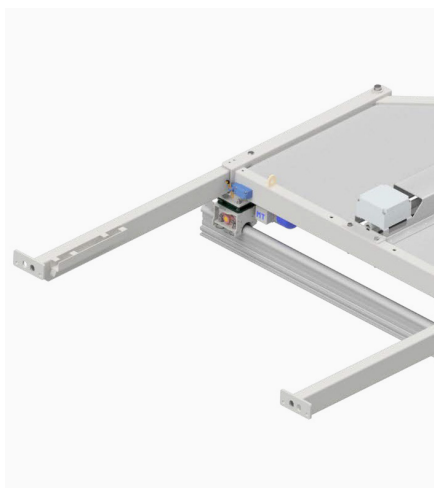

Roca Roof Trolley

The **Roca roof trolley** has a fixed reach of 1300mm and has a maximum working load limit of 700kg.

The **Roca Highbody** has a fixed reach of 1295mm and has a maximum working load limit of 700kg. The **Roca Highbody** is particularly suited to situations where you need to lift the access stage above the roof to move to another elevation. Or park the stage on the roof.



Armstrong Roof Trolley

The **Armstrong roof trolley** has an adjustable reach of 600-1400mm and has a maximum working load limit of 700kg.

All trolleys require 3 Phase power & can be folded back when not in use.

PERFORMANCE

Rostek Roof Trolleys are designed to carry suspended access equipment according to EN1808.

INSTALLATION

Installation must only be carried out by Rostek certified installation companies, and in accordance with all manufacturer requirements.

MAINTENANCE

As per AS/NZS 1891.4 the Rostek Roof trolley must be certified every 12 months by an Accredited Rostek Certification technician. All of the exposed materials in the system have specified as naturally corrosion resistant, or have been coated with sacrificial coatings to prevent oxidation of the base material. It is important to consider that in some environments the system may need to be cleaned to gain the best possible life expectancy from the materials.

WARRANTY

Rostek grants a warranty for 12 months from the date of purchase of the device. The warranty covers; defects in material, defects in workmanship, anti-corrosion coating defects.

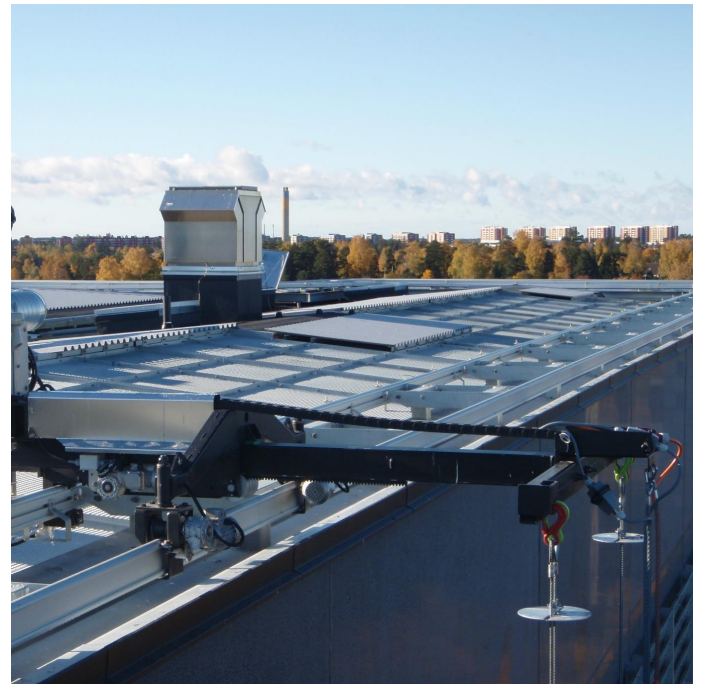

ENVIRONMENTAL

Alta Safety is committed to reducing its impact on the environment.

We will strive to improve our environmental performance over time and to initiate additional projects and activities that will further reduce our impacts on the environment.

Our commitment to the environment extends to our customers, our staff, and the community in which we operate. We are committed to supplying products with primary components made of recyclable material and is supplied with minimum packaging to retain its structure and integrity during transit.

We will continually measure our environmental impacts and aim to reduce these.

TECHNICAL DRAWING – ROSTEK ARMSTRONG LIGHT ROOF TROLLEY

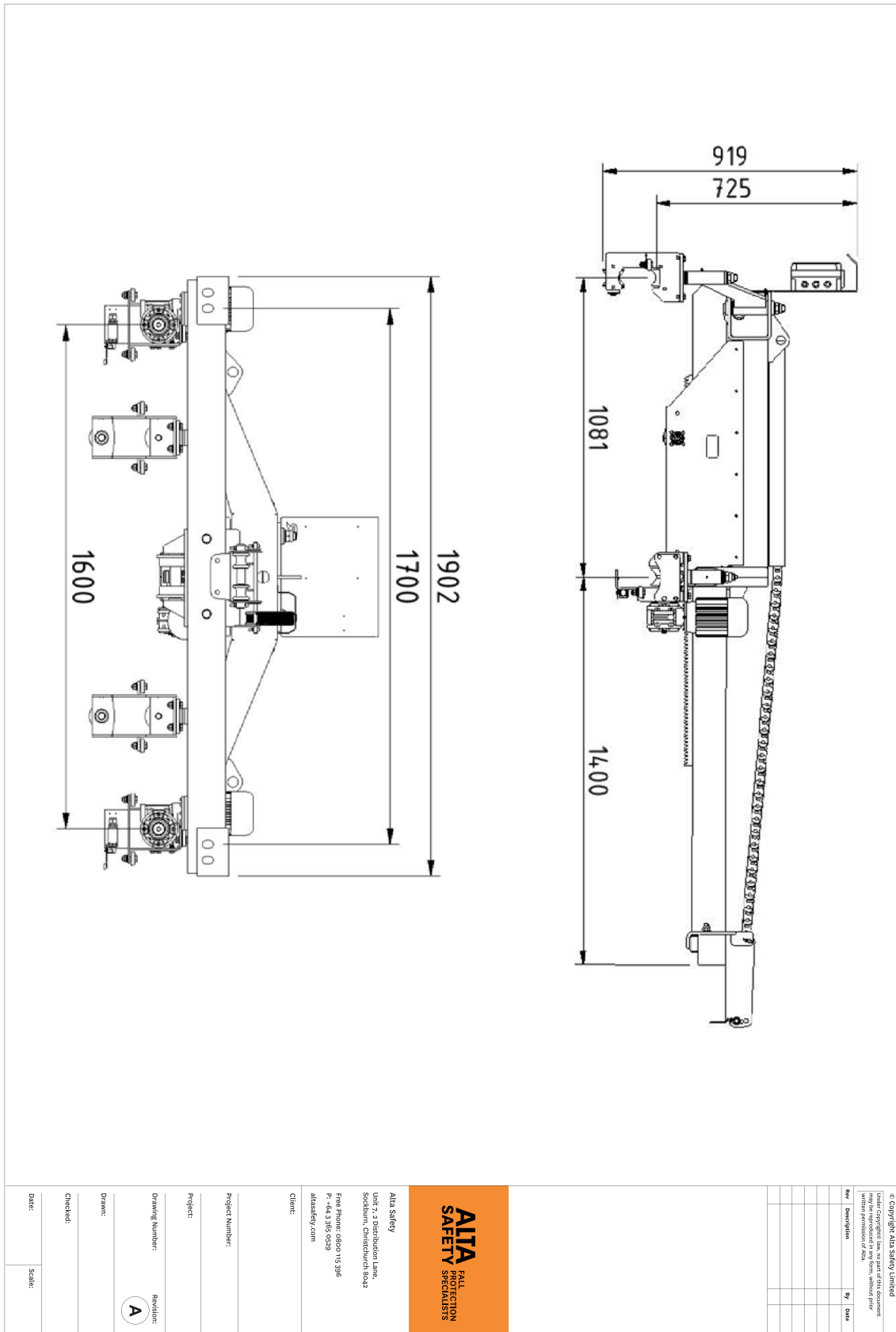

TECHNICAL DRAWING – ROSTEK ROCA LIGHT ROOF TROLLEY

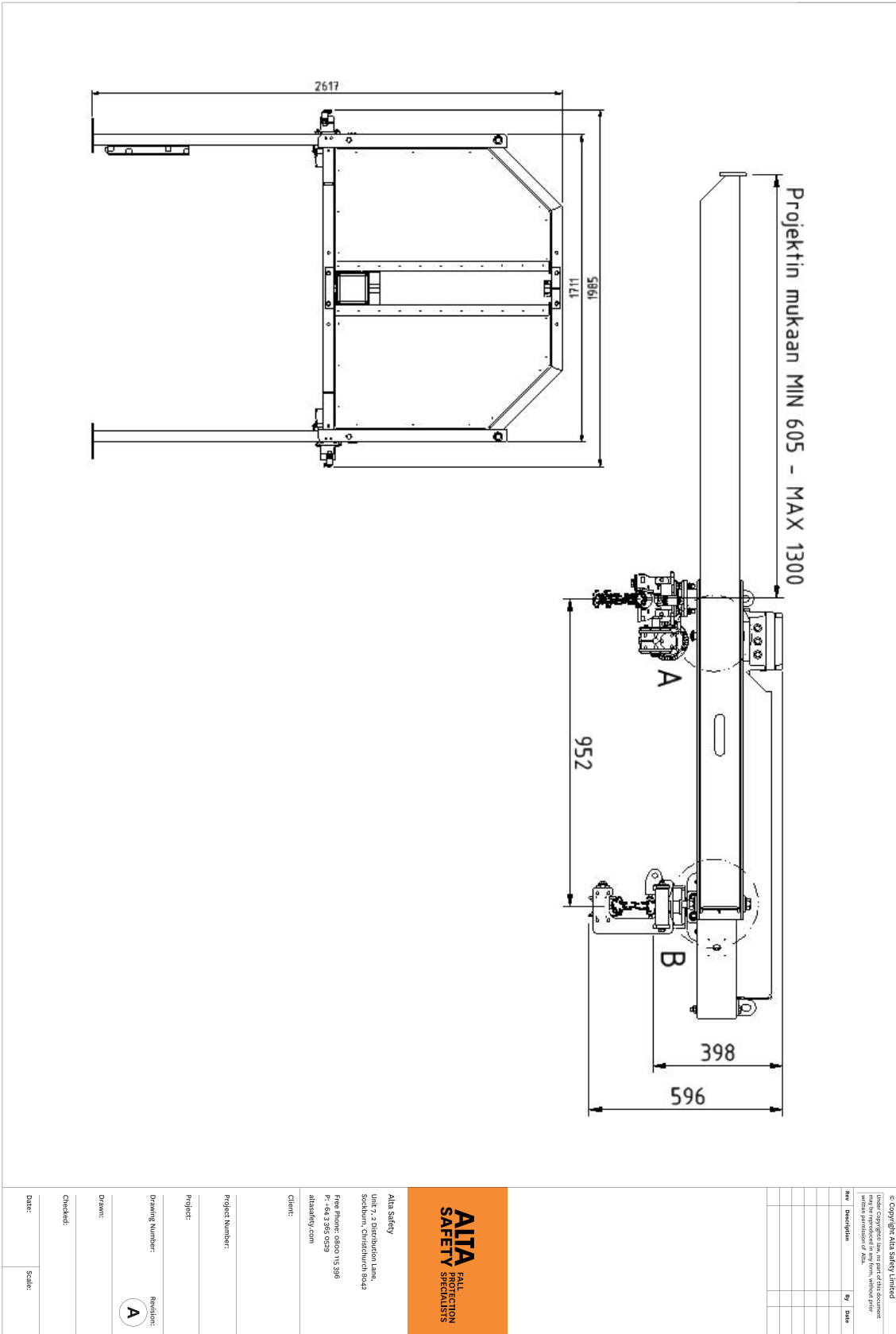

CHRISTCHURCH

Unit 7, 2 Distribution Lane,
Sockburn, Christchurch 8042

AUCKLAND

B7 / 930 Great South Road
Penrose, Auckland 1061

WELLINGTON

Unit 8, 16 Jamaica Drive,
Grenada North, Wellington 5028

design@altasafety.com



TECHNICAL DRAWINGS KEY



Rate to
15kN



Person
Capacity



Abseil



Fall Arrest



Restraint
Technique