

## SAFETYLINK

### FASTFIT MODULAR GUARD RAILS Modular Guard Rails

Permanent system that provides safety from falling to elevated areas.

FastFit Guard Rails are suitable for numerous applications where a physical barrier is required to provide safety from falling.

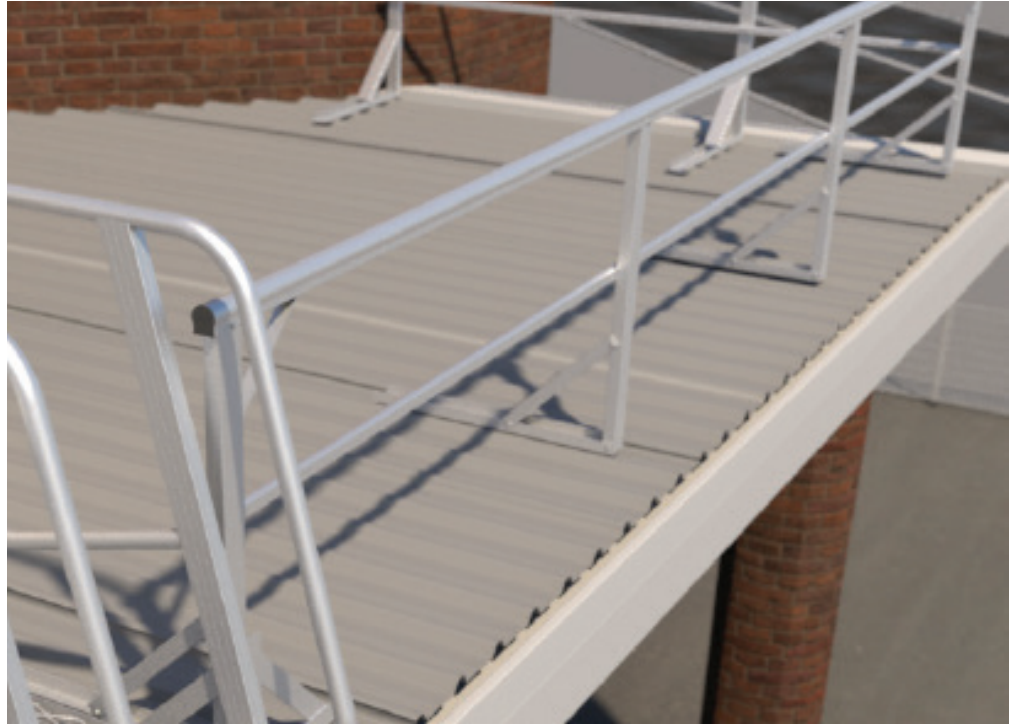

## HOW IT IS USED

FastFit Guard Rails can be mounted directly to a roof or to a parapet in areas that have a high risk of falling.

Ideal for use around plant and equipment that requires regular scheduled maintenance.

## HOW IT WORKS

Mounted to the roof surface or parapet, Guard Rails provide a compliant barrier to prevent personnel being exposed to a fall hazard.





---

## PERFORMANCE

Safetylink FastFit Guard Rails Conform to AS 1657:2013.

---

## INSTALLATION

Installation should be carried out by a Manufacturer trained installer who have completed the required training modules and hold the relevant training certificates.

---

## MAINTENANCE

Visual inspection for any damage or loose fixings must be done periodically and prior to installation. No certified maintenance required. Basic wear and tear preventative maintenance is recommended as per manufacturer's specifications and recommendations.

---

## WARRANTY

Warranty for 10 years and 2 years installation.

---

## ENVIRONMENTAL

PBI Height Safety is committed to reducing its impact on the environment.

We will strive to improve our environmental performance over time and to initiate additional projects and activities

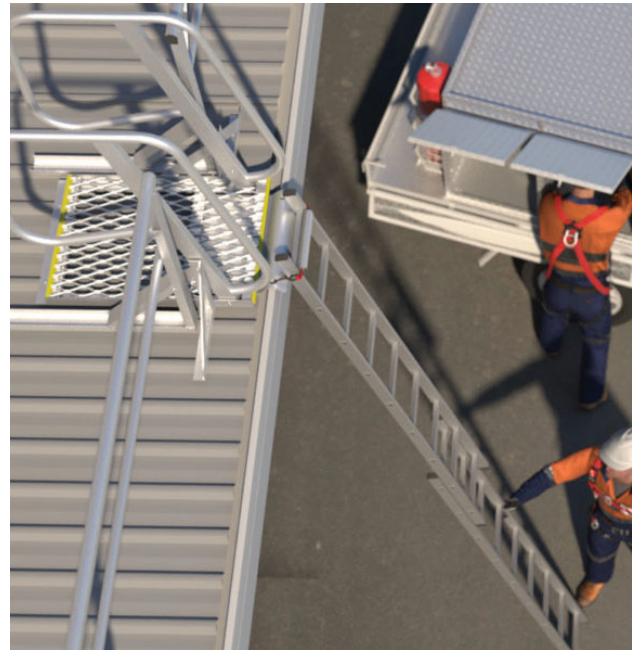

that will further reduce our impacts on the environment.

Our commitment to the environment extends to our customers, our staff, and the community in which we operate. We are committed to supplying products with primary components made of recyclable material and is supplied with minimum packaging to retain its structure and integrity during transit.

We will continually measure our environmental impacts and aim to reduce these impacts.

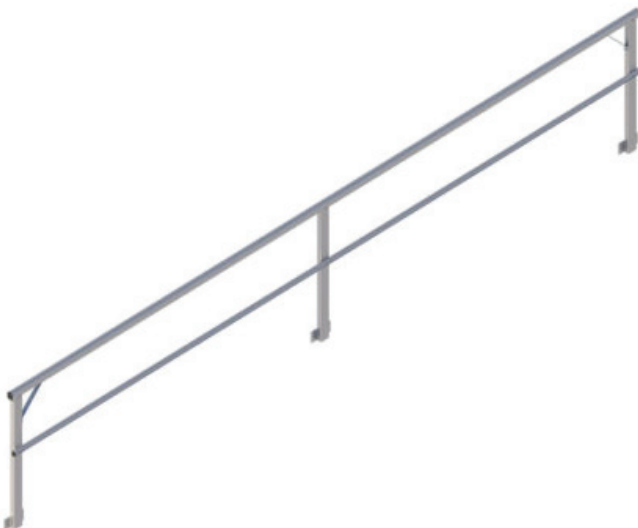



Folding FastFit Guardrail - Concrete Base Mount



© Copyright PBI Height Safety Limited  
 Under Copyright© law, no part of this document  
 may be reproduced in any form, without prior  
 written permission of PBI.

Rev	Description	By	Date



**PBI Height Safety Limited**

10 Holt Place, PO Box 39048,  
 Harewood, Harewood,  
 Christchurch 8053, Christchurch 8454,  
 New Zealand New Zealand

Free Phone: 0800 357 003  
 P: 0800 357 0093

[pbiheightsafety.com](http://pbiheightsafety.com)

Client: \_\_\_\_\_

Project Number: \_\_\_\_\_

Project: \_\_\_\_\_

Drawing Number: \_\_\_\_\_ Revision: \_\_\_\_\_

A

Drawn: \_\_\_\_\_

Checked: \_\_\_\_\_

Date: \_\_\_\_\_ Scale: \_\_\_\_\_

### Folding FastFit Guardrail - Roof Mount

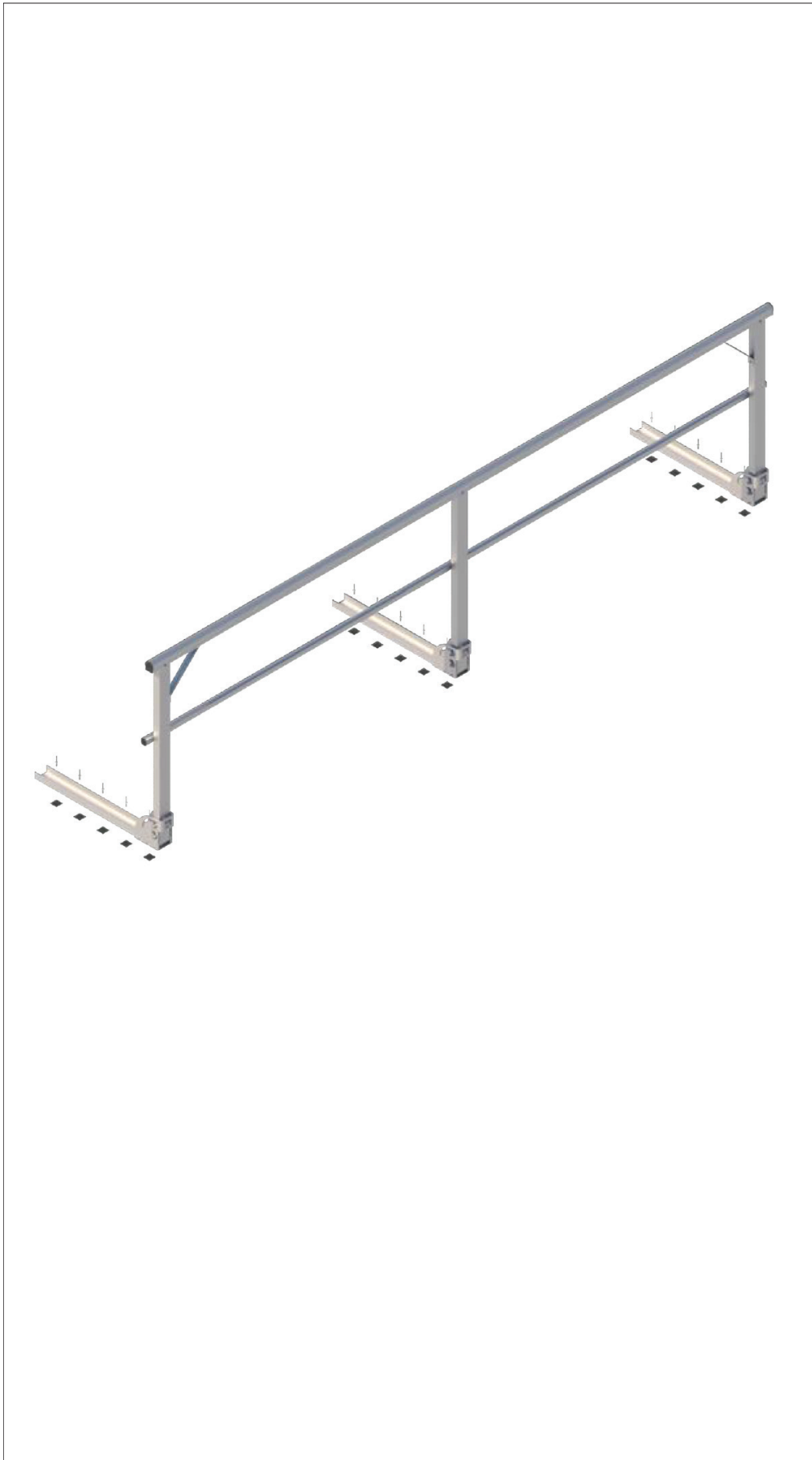

© Copyright PBI Height Safety Limited  
 Under Copyright© law, no part of this document  
 may be reproduced in any form, without prior  
 written permission of PBI.

Rev	Description	By	Date



**PBI Height Safety Limited**  
 10 Holt Place, PO Box 39048,  
 Harewood, Harewood,  
 Christchurch 8053, Christchurch 8454,  
 New Zealand New Zealand  
 Free Phone: 0800 357 003  
 P: 0800 357 0093  
 pbiheightsafety.com

Client: \_\_\_\_\_

Project Number: \_\_\_\_\_

Project: \_\_\_\_\_

Drawing Number: \_\_\_\_\_ Revision: **A**

Drawn: \_\_\_\_\_

Checked: \_\_\_\_\_

Date: \_\_\_\_\_ Scale: \_\_\_\_\_



**Fixed FastFit Guardrail - Concrete Base Mount**

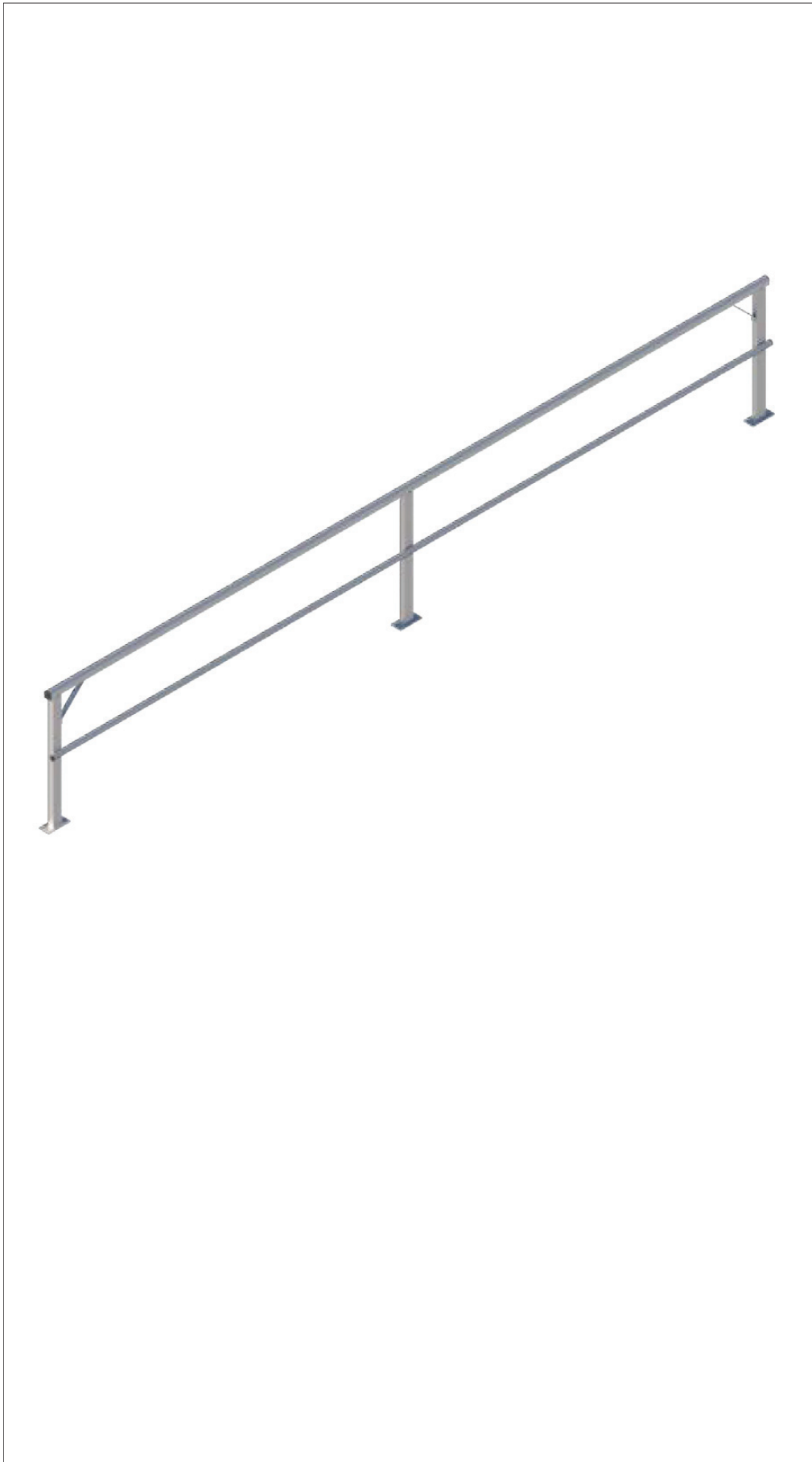

© Copyright PBI Height Safety Limited  
 Under Copyright© law, no part of this document  
 may be reproduced in any form, without prior  
 written permission of PBI.

Rev	Description	By	Date



**PBI Height Safety Limited**  
 10 Holt Place, PO Box 39048,  
 Harewood, Harewood,  
 Christchurch 8053, Christchurch 8454,  
 New Zealand New Zealand  
 Free Phone: 0800 357 003  
 P: 0800 357 0093  
 pbiheightsafety.com

Client: \_\_\_\_\_

Project Number: \_\_\_\_\_

Project: \_\_\_\_\_

Drawing Number: \_\_\_\_\_ Revision: **A**

Drawn: \_\_\_\_\_

Checked: \_\_\_\_\_

Date: \_\_\_\_\_ Scale: \_\_\_\_\_



**Fixed FastFit Guardrail - Concrete Side Mount**

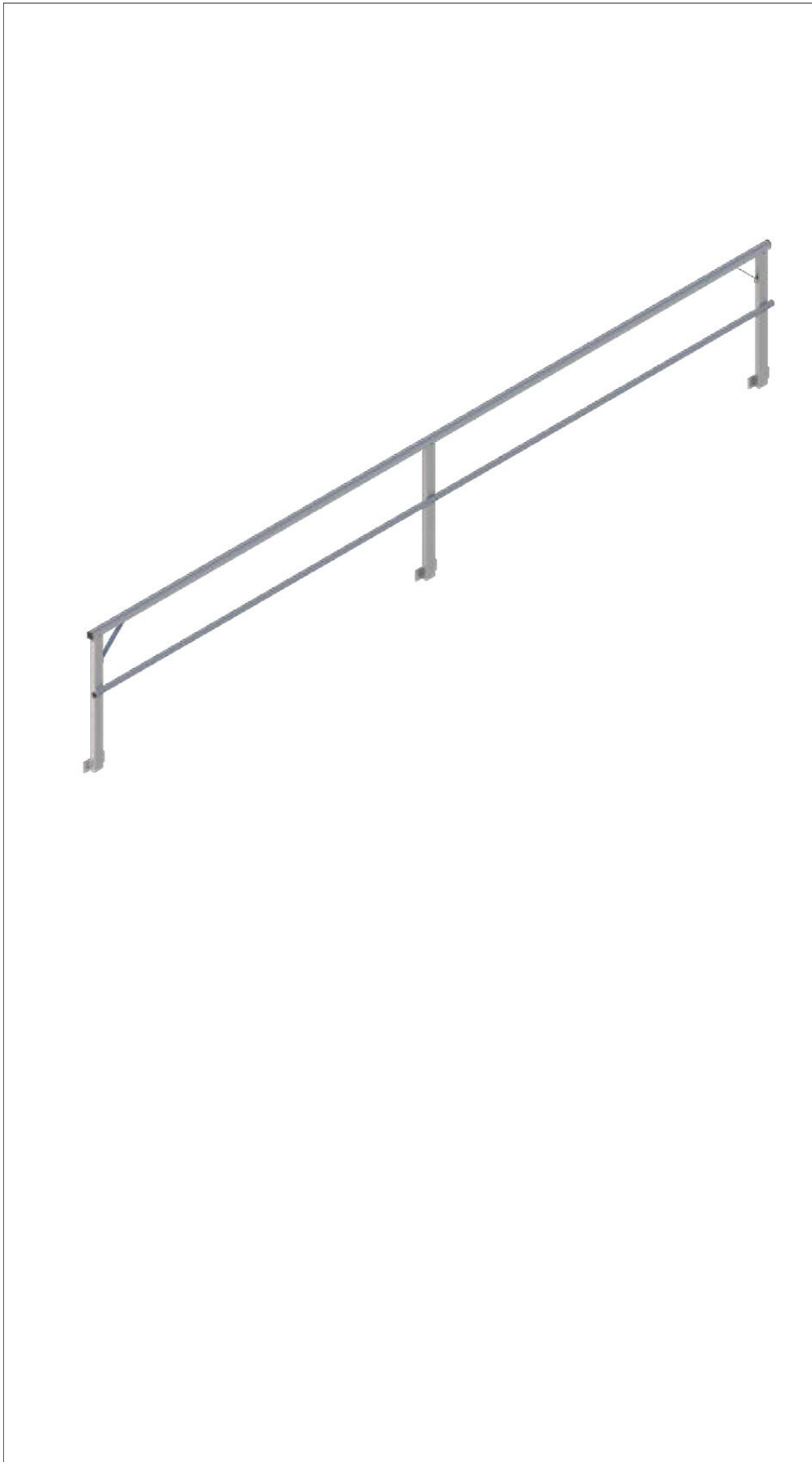

© Copyright PBI Height Safety Limited  
 Under Copyright© law, no part of this document  
 may be reproduced in any form, without prior  
 written permission of PBI.

Rev	Description	By	Date



**PBI Height Safety Limited**

10 Holt Place, PO Box 39048,  
 Harewood, Harewood,  
 Christchurch 8053, Christchurch 8454,  
 New Zealand New Zealand

Free Phone: 0800 357 003  
 P: 0800 357 0093

[pbiheightsafety.com](http://pbiheightsafety.com)

Client: \_\_\_\_\_

Project Number: \_\_\_\_\_

Project: \_\_\_\_\_

Drawing Number: \_\_\_\_\_ Revision: \_\_\_\_\_

A

Drawn: \_\_\_\_\_

Checked: \_\_\_\_\_

Date: \_\_\_\_\_ Scale: \_\_\_\_\_

**PBI HEIGHT SAFETY**

**NEW ZEALAND OFFICES**



**CHRISTCHURCH**  
10 Holt Place  
Harewood  
Christchurch 8053

**AUCKLAND**  
D23 / 930 Great South Road  
Penrose  
Auckland 1061

[info@pbiheightsafety.com](mailto:info@pbiheightsafety.com)



**TECHNICAL DRAWINGS KEY**



**Rate to**  
15kN



**Person**  
Capacity



**Abseil**



**Fall Arrest**



**Restraint**  
Technique